

MODEL # CZC141.0/17WS19

P/N:

MK7110

REV. .

APPROVED BY:

REVISIONS		
REV.	DESCRIPTION	DATE
△	PLM系統初始版本為A版	2024/05/27
△		
△		
△		
△		

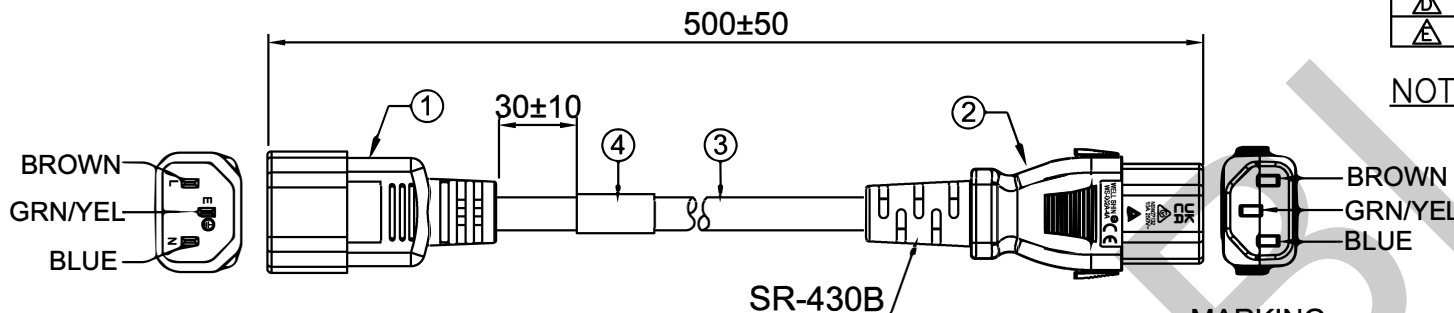

NOTES:

1. 外箱標籤請參考2720-0384-1 最新版.

MARKING:

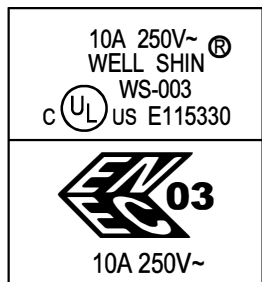

⑤
10 條一束
10 PCS IN ONE BUNDLE

MARKING:

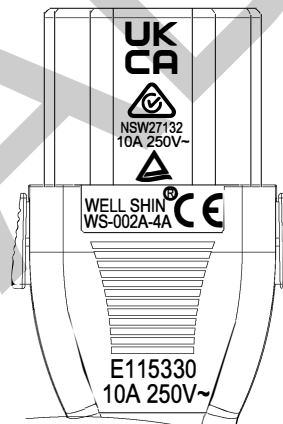

upper cover(上蓋)
*下蓋空白不雷雕

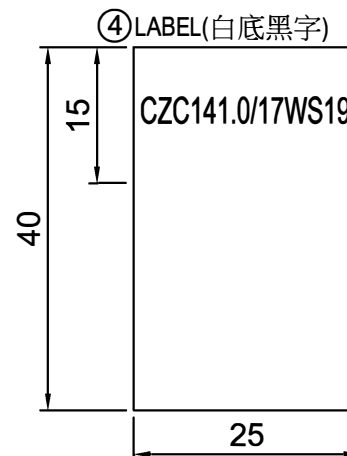

ITEM	DESCRIPTION	COLOR	QTY	頭	尾	線種	線規	芯線數	溫度	顏色	總長度
①	WS-003 10(A) 250(V) APPROVAL: UL,CUL,ENEC	BLACK	1	WS-003	WS-002A-4A	SJTW+H05VV-F+60227 IEC53(RVV)	17AWG+1.0MMSQ	3G	105°C	BLACK	500mm
②	WS-002A-4A 10(A) 250(V) APPROVAL: UL,CUL,RCM,TUV,UKCA,CE	BLACK	1	MARKING: Ⓜ FOR DONG-GUAN PLANT, Ⓚ FOR KUN-SHAN PLANT							
③	SJTW 17AWG 3C 105°C + H05VV-F 3G 1.00MMSQ + 60227 IEC 53(RVV) 300/500 3G 1.00MMSQ APPROVAL: UL,CUL,EUROPEAN,CCC,CE	BLACK	1	SIGNATURE		MK Cable					
④	LABEL	---	1	ENGINEER BY:			PRODUCT NO.:		DATE: 2024/05/27		
⑤	PE膜(PE FILM)	CLEAR	1	MANAGER BY:			UNIT: mm		SHEET: 1 OF 1		REV.
				CHECKED BY:			DWG NO: 2720-0400		A		
				DRAWN BY:	陳金德						